

Axial Fans

R13_-4530A-4T2-3500

450mm

Fan with wall plate

Type:
R13P-4530A-4T2-3500

Code:
0313-4-0189

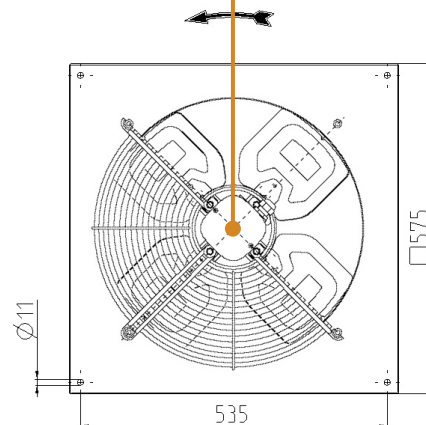
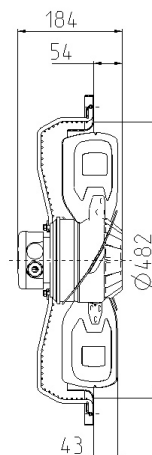

Weight:
11,4kg

Fan with guard grill

Type:
R13R-4530A-4T2-3500

Code:
0313-4-0000

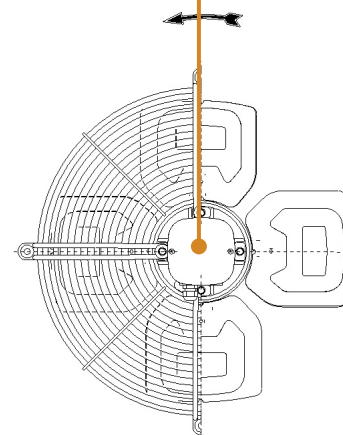
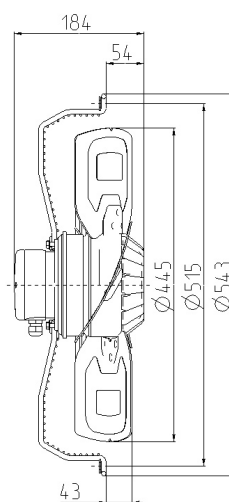

Weight:
6,3kg

Fan without guard grill

Type:
R13E-4530A-4T2-3500

Code:
0313-4-0188

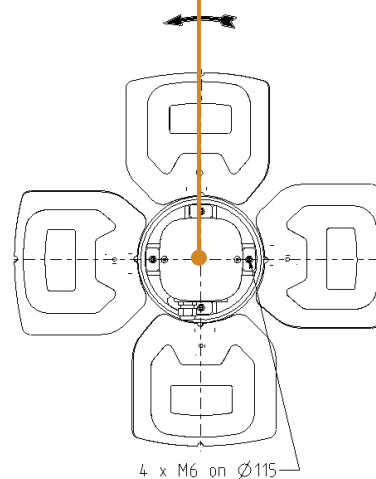
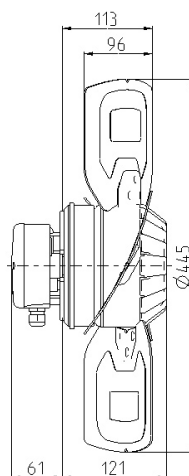

Weight:
6,3kg

Aerodynamic characteristic:

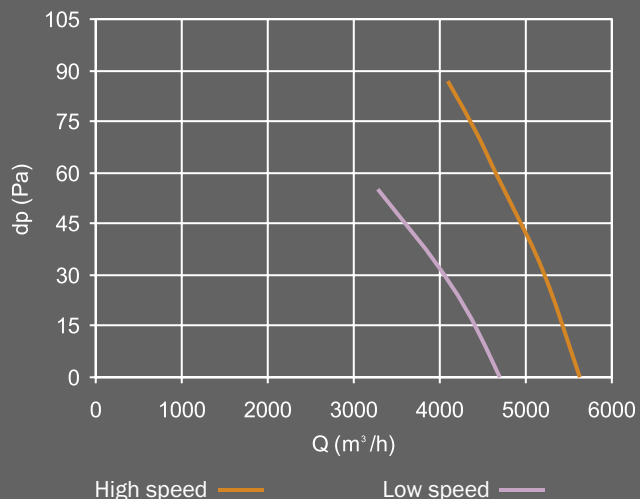

Performance Data:

3~400V D/Y 50Hz
 $P_1 = 360 / 220W$
 $n = 1330 / 1070min^{-1}$
 $I = 0,76 / 0,38A$
 $t_R = 40^\circ C$
 $Lwa = 78 / 71dB(A)$
 Connection: terminal box
 Ins.Cl. F
 IP54

Notes:

Fan characteristic measured in short bell mouth with guard grill